

CFP-500

Dual Line Dialer

Installation Manual

• Version 1.0 •



WARNING: This manual contains information on limitations regarding product use and function and information on the limitations as to liability of the manufacturer. The entire manual should be carefully read.

Table of Contents

Section 1: Introduction	1	Section 4: Programming the CFP-500	6
1.1 General Features of the CFP-500	1	4.1 How to program using the CFP-550 Handheld Programmer	6
1.2 Codes, Standards and Installation Requirements	1	4.2 DLS Programming.....	12
1.3 Technical Support and General Information	2	4.3 Panel Programming Section Descriptions.....	12
Section 2: Installing and Wiring the CFP-500	3	Section 5: Programming Worksheets	16
2.1 Unpacking the CFP-500.....	3	5.1 Dialer Programming Worksheets.....	16
2.2 Wiring the CFP-500.....	3	5.2 Panel Programming Worksheets	21
Section 3: CFP-500 Operation	5	Section 6: Warranty and Warning Information	22
3.1 LED Indicators	5	6.1 Warning	22
3.2 Communication with the Fire Alarm Control Panel.....	5	6.2 Limited Warranty.....	24
3.3 Phone Line Communication	5	Appendix A: Table of Reporting Codes	25
		Appendix B: Table of Compatible Receivers	27

Section 1: Introduction

The CFP-500 is a dual line dialer that will communicate all alarms, supervisory and trouble conditions to a Central Station using Contact ID, SIA or 10/20 bps communication formats. The CFP-500 will support the CFP-102 or CFP-105 Fire Panel. The CFP-550 Handheld Programmer must be used to program the CFP-500 Dialer.

1.1 General Features of the CFP-500

- Supports all zone alarm, supervisory, and trouble conditions
- Supports all panel troubles
- Programmable through CFP-550 Handheld Programmer
- Supports 10/20 bps, SIA, Contact ID, and Pager Formats
- Three telephone numbers
- Fully programmable test transmission
- Automatic reporting codes for SIA and Contact ID formats
- 128-event buffer with date and time stamp
- Communicator call directions by group
- Swinger shutdown options available for all events
- Module current rating: 40mA standby / 65mA when dialing
- Module voltage rating: 19 VDC to 27.5 VDC

1.2 Codes, Standards and Installation Requirements

1.2.1 Relevant Codes and Standards

The CFP-500 Dual-Line Digital Dialer is designed to meet the DACT requirements of NFPA 72, 1996 edition UL 864, Control Units for fire Protective Systems, 1996 edition and in Canada, CAN/ULC-S527, Standard for Control Units for Fire Alarm Systems, 1999 edition.

1.2.2 General Installation Requirements

Manufacturer's Documents

When installing the CFP-500, refer to this manual and the manual for the control panel into which this module is being installed. This dialer requires programming. Programming is done using the CFP-550 programmer. Refer to the CFP-550 operating instructions for details on programming using the CFP-550.

Field Wiring

Field wiring recommendations in these documents are intended as guidelines. All field wiring must be installed in accordance with NFPA 70 National Electrical Code and in Canada with the most current National Electrical Code and with all relevant local codes and standards and the Authority Having Jurisdiction.

1.3 Technical Support and General Information

For technical support from DSC: Call toll free 1-800-387-3630 (Canada & US)

For general product information visit our web site: www.dsc.com

1.3.1 System Verification

The complete fire alarm system must be verified for proper installation and operation when:

- the initial installation is ready for inspection by the Local Authority Having Jurisdiction;
- any system component is added, changed or deleted;
- any programming changes are made;
- system wiring has been altered or repaired;
- system failure due to external influences such as lightning, water damage or extended power outages has occurred.

1.3.2 Standby Power

The CFP-102/CFP-105 Fire Panel provides standby battery support for lead-acid rechargeable batteries. The required capacity of the standby batteries must be calculated using the charts and tables within the CFP-102/CFP-105 *Installation Manual* for the period as required by national or local codes and standards. Even though the calculation table within the CFP-102/CFP-105 *Installation Manual* includes a safety margin, lead-acid batteries commonly used for standby can have variable capacity as a result of age and ambient conditions. Periodic inspection for damage and the batteries' ability to support the attached equipment is highly recommended.

Section 2: Installing and Wiring the CFP-500

2.1 Unpacking the CFP-500

The basic CFP-500 package includes the following components:

- Dialer
- 4-pin polarized locking cable assembly
- Four #4 self-locking nuts
- Installation manual
- Four nylon spacers

2.2 Wiring the CFP-500

NOTE: Ensure that standby calculations are done before installing the dialer. See the CFP-102/CFP-105 Fire Panel Installation Manual for all power information and calculation charts. The current rating for the CFP-500 is:

- 40 mA standby current
- 65 mA alarm current (when dialing)

2.2.1 Mount the CFP-500

The CFP-500 is located inside the main panel cabinet according to the following diagram:

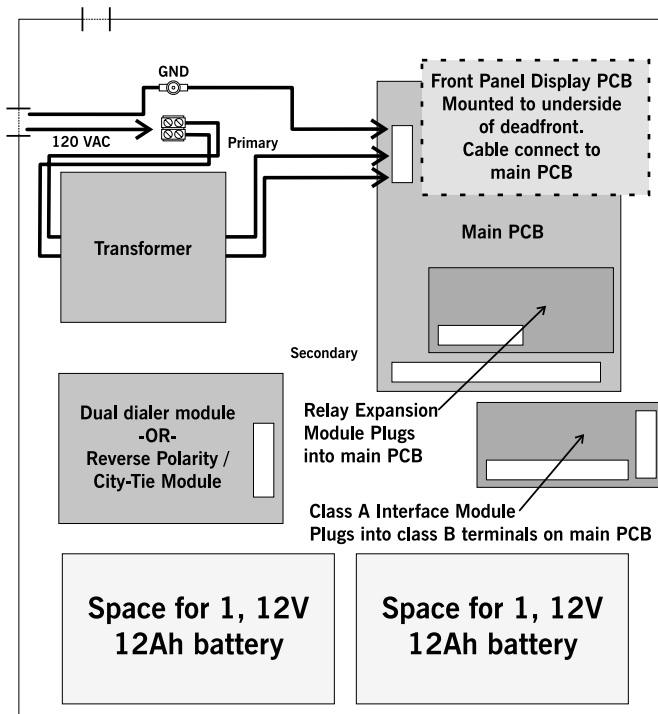

2.2.2 Connect the CFP-500

The CFP-500 requires connection of the Secur-bus from the dialer to the main panel using the provided 4-pin polarized locking cable assembly. Up to two telephone lines are connected to the Tip/Ring/T1/R1 terminals.

Connect the dialer according to the following diagram:

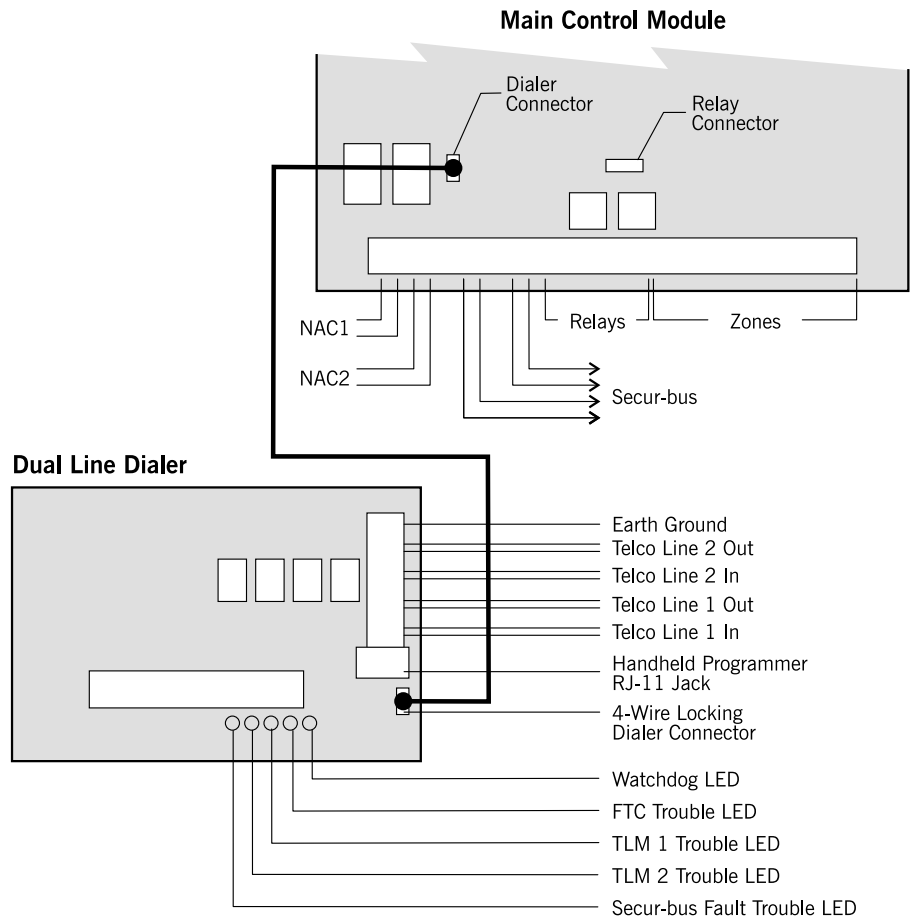

Section 3: CFP-500 Operation

3.1 LED Indicators

The dialer's operating status is visible from its five LED indicators. These indicators are located on the dialer. Each indicator is described in the following table:

#	Indicator	LED Color	Activates when...
1	Secur-bus Fault	Yellow	the Secur-bus connection to the main panel has failed
2	TLM2 Trouble	Yellow	there is a trouble on telephone line #2
3	TLM1 Trouble	Yellow	there is a trouble on telephone line #1
4	FTC Trouble	Yellow	the dialer is unable to communicate
5	Watchdog	Green	the dialer is functioning normally; LED flashes ½ second on, ½ second off

3.2 Communication with the Fire Alarm Control Panel

When connected to the FACP properly, the Watchdog LED will flash at a rate of ½ second on/off when power is applied to the FACP. The dedicated dialer will transmit all events that occur on the FACP if programmed to do so. Any troubles that occur on the dedicated dialer will be shown on the appropriate LED and communicated (if enabled) as well as causing a common trouble condition on the FACP. If the FACP should lose communication with the dialer a common trouble condition will also be generated.

3.3 Phone Line Communication

The dedicated dialer is equipped with two phone line connections. When an event occurs that initiates communications, the first attempt at dialing will be on telephone line #1. If the attempt fails, the dialer will then select telephone line #2 for the next attempt at dialing. This will continue until the maximum number of dialing attempts is reached. Please note that on the first attempt to telephone line #1, if a telephone line trouble exists on line #1 and not line #2, then the first attempt will start on line #2.

Section 4: Programming the CFP-500

4.1 How to program using the CFP-550 Handheld Programmer

4.1.1 Connect the CFP-550 to the Dialer

The CFP-550 connects to the dialer via the RJ-11 jack mounted on the dialer. An RJ-11 connector cable is provided with the handheld programmer. Refer to the wiring diagram in "Connect the CFP-500" on page 4 for the location of the RJ-11 jack.

Once the programmer is connected, it will power up and remain idle until programming is initiated.

4.1.2 Programming using the CFP-550

To program, follow these steps:

1. Press [*].
The programmer display will read "Enter Module Address."
The dialer's module address = 11.
The control panel address = 02
2. Enter [11] (for example).
The programmer display will read "Enter Installer Code" The default code = 2600.
3. Enter the installer's code.
The display will read "Enter Section Number"
4. Enter a valid 3-digit programming section number to program that section.
5. Enter the programming data required by the selected programming section. Use the arrow keys (< >) to view the programming data in the selected programming section.

To return to "Enter Module Address", press [#] from the "Enter Section Number" display.

4.1.3 Entering Hexadecimal Digits

On occasion, hexadecimal (HEX) digits may be required. To program a HEX digit (A-F), press the [*] key at any HEX data entry section. The panel will enter the HEX programming mode. The following indicates which number should be pressed to enter the corresponding HEX digit:

1 = A 2 = B 3 = C 4 = D 5 = E 6 = F

If another HEX digit is required press the [*] key followed by the corresponding number entry. After every HEX entry, the programmer will return to standard number entry.

4.1.4 Dialer Programming Section Descriptions

Telephone Numbers, Section [001]-[003] and [411] for DLS Phone Number

Telephone numbers can be up to 32 digits, allowing the addition of special digits, if required. To program the telephone number, enter numbers 0 through 9 as required. Hexadecimal digits (B-F) can also be used to perform the following functions:

HEX (B)-simulates the [*] key on a touch tone telephone

HEX (C)-simulates the [#] key on a touch tone telephone

HEX (D)-forces the panel to search for dial tone

HEX (E)-forces the panel to pause for 2 seconds

HEX (F)-end of telephone number marker

Three telephone numbers can be programmed. When programming, press the [#] key once the telephone number is entered to exit the programming section.

Account Codes, Sections [011]-[012]

The account code identifies the panel to the central station when a communication is sent. Use up to four digits for account codes.

When communicating events via the first or third telephone number, the **first account code** is used. The second telephone number uses the **second account code**.

Dialing Options, Section [051]-[052]

The options in programming sections [051]-[052] are explained below. Where applicable, other sections of the manual will be referenced for more information regarding the feature.

The default setting for each option (ON or OFF) is indicated with an *.

- **[051] First Communicator Options**

- [1] - [3] For future use
- [4] Third Telephone Number Enable / Disable
 - ON = The third telephone number will be used for alternate dialing or backup (see following option 5).
 - *OFF = The third telephone number will not be used.
- [5] Third Telephone Number Options
 - ON = Alternate Dialing Enabled. After each dialing attempt, the communicator switches between the first and third telephone numbers until the maximum number of dialing attempts have been made to each number.
 - *OFF = Third Number Backup. If all attempts to communicate to the first telephone number fail, the dialer will use the third telephone number. If all attempts to communicate to the third number fail, a failure to communicate trouble will be generated.
- [6] Dialing Format Options
 - ON = The dialer will use pulse (rotary) dialing.
 - *OFF = The dialer will use DTMF dialing (see following option 7).
- [7] DTMF Crossover Options
 - ON = If DTMF dialing is enabled in previous option 6, the dialer will use DTMF dialing for the first four attempts. If unsuccessful, the dialer will switch to pulse (rotary) dialing for the remaining attempts.
 - *OFF = If DTMF dialing is enabled in previous option 6, the dialer use DTMF dialing for all dialing attempts.
- [8] Event Buffer Swinger Options
 - *ON = Once an event reaches its swinger shutdown limit, it will no longer log to the event buffer until the swinger shutdown is reset. This avoids filling the Event Buffer with repeated events. See Section 4.2.10 "Swinger Shutdown" for more information.
 - OFF = Event buffer logs events past swinger shutdown.

- **[052] Second Communicator Options**

- [1] SIA Reporting Code Options
 - See "Communicator Format Options, Section [021]" on page 9 for more information.
 - ON = SIA sends programmed reporting codes
 - *OFF = SIA sends automatic reporting codes
- [2] SIA Maximum Events Per Round Options
 - See "Communicator Format Options, Section [021]" on page 9 for more information
 - ON = SIA sends maximum of 20 events per round
 - *OFF = SIA sends maximum of 8 events per round
- [3] Contact I.D. Options
 - See "Communicator Format Options, Section [021]" on page 9 for more information
 - ON = Contact ID sends programmed reporting codes
 - *OFF = Contact ID sends automatic reporting codes
- [4] Test Transmission Dialing Options
 - See "Test Transmissions, Sections [041]-[042]" on page 11 for more information
 - *ON = Test transmission alternates telephone lines.
 - OFF = Test transmission uses first available line.
- [5] – [6] For Future Use
- [7] DLS Callback
 - ON = DLS Callback Enabled. If the remote computer connects with the dialer and this option is enabled, the dialer will disconnect from the computer and call the DLS phone number programmed. Once the DLS connection is re-establish communications will begin.

- *OFF = DLS Callback Disabled. When the remote computer connects to the dialer communications will begin.
- [8] DLS Double Call
 - ON = DLS Double Call Enabled. If there is more than 7 seconds delay and less than the programmed DLS Double Call window timer between the first/second and the second/third ring, the dialer will answer the incoming call.
 - *OFF = DLS Double Call Disabled. The dialer will require the programmed number of rings before answering an incoming call.
- **[053] International Communicator Options Code**
 - [1] Force Dial Options
 - ON = Force Dialing Enabled. If the first attempt by the panel to call the monitoring station fails, on every subsequent attempt the panel will dial regardless of the presence of dial tone.

NOTE: *The panel will go off-hook, search for dial tone for 5 seconds, hang-up for 20 seconds, of off-hook, search for dial tone for 5 seconds. then dial (assuming no presence of dial tone).*
 - *OFF = Force Dialing Disabled. The panel will not dial the programmed telephone number if dial tone is not present.
 - [2] Busy Tone Options
 - ON = Busy Tone Detection Enabled. If these tones are detected, the communicator will disengage the phone line and try to place the call again following the “Delay Between Dialing Attempts”.
 - *OFF = Busy Tone Detection Disabled, The communicator will use the standard dialing procedure for every attempt.
 - [3] Pulse Dial Options
 - ON = Pulse Dialing Make/Break Ratio is 33/67.
 - *OFF = Pulse Dialing Make/Break Ratio is 40/60.
 - [4] Handshake Options
 - ON = 1600 Hz Handshake. The communicator responds to a 1600 Hz handshake for bps formats.
 - *OFF = Standard Handshake. The communicator responds to the handshake designated by the format selected (1400 or 2300 Hz).
 - [5] I.D. Tone Options
 - ON = I.D. Tone Enabled. After the telephone number is dialed, the panel will emit a tone (as specified by Option 6) for 500 ms every 2 seconds to indicate that it is a digital equipment call, not voice.
 - *OFF = I.D. Tone Disabled.
 - [6] I.D. Tone Frequency
 - ON = 2100 Hz I.D. Tone Enabled. This option requires option 5 to be enabled.
 - *OFF = 1300 Hz I.D. Tone Enabled. This option requires option 5 to be enabled.
 - [7] - [8] For future use

Communicator Call Directions, Sections [031]-[035]

Communicator call directions must be programmed to indicate which telephone numbers the dialer will use to communicate events. The dialer can send reporting codes to the first and/or second telephone number(s). By default, all events are sent to the first telephone number.

Communicator call directions are programmed separately for each of the following types of reporting codes:

- zone alarms and restorals [031]
- supervisory zone alarms and restorals [032]
- zone troubles and restorals [033]
- maintenance troubles and restorals [034]
- test transmissions [035]

Communicator Format Options, Section [021]

A 2-digit entry is required for each telephone number. Only one communicator format may be programmed for each telephone number. The following communicator formats are available for the dialer:

1. 10 or 20 bps Pulse
2. Contact ID
3. SIA
4. Pager

Each format is explained below.

Pulse Formats

Depending on the pulse format selected the panel will communicate using the following:

- 10 bps, 1400 Hz handshake
- 10 bps, 2300 Hz handshake
- 20 bps, 1400 Hz handshake
- 20 bps, 2300 Hz handshake

Obey the following when using the Pulse format:

- The digit '0' will send no pulses and is used as a filler.
- Account numbers must be four digits. . If a 3-digit code is required, program the fourth digit as '0'.
- The digit '0' is not used in this format—substitute with HEX digit 'A'.
- All reporting codes must be two digits. If a single-digit code is required, program the second digit as '0'.
- To prevent the panel from reporting an event, program the reporting code as [00] or [FF].

Contact ID

Contact ID is a specialized format that will communicate more information quickly using tones rather than pulses.

When using Contact ID, obey the following:

- Account numbers must be four digits.
- The digit '0' is not used in this format—substitute with HEX digit 'A'.
- All reporting codes must be two digits.
- To prevent the panel from reporting an event, program the reporting code as [00] or [FF].

Contact ID Communicator Options [052] #3

If **Contact ID Uses Automatic Reporting Codes** is selected, the dialer will automatically generate a reporting code for each event. These identifiers are listed in Appendix A. If the reporting code [00] is programmed, no transmission will be sent.

If the **Contact ID uses Programmed Reporting Codes** option is selected, the dialer will only communicate events for which valid reporting codes are programmed.

Consult the following table for clarification of this feature:

Reporting Code Entry	Programmed Reporting Codes	Automatic Reporting Codes
00	No Transmission	No Transmission
FF	No Transmission	Automatic reporting code sent
01-FE	01-FE sent	Automatic reporting code sent

SIA

The SIA format communicates information quickly using frequency shift keying (FSK) rather than pulses. The 2-digit reporting code is used to identify the zone.

SIA Communicator Options [052] #1-2

If the **SIA Sends Automatic Reporting Codes** option is selected, the dialer will automatically generate a reporting code for each event. These identifiers are listed in Appendix A. If the reporting code [00] is programmed, no transmission will be sent.

If the **SIA Sends Programmed Reporting Codes** option is selected, the dialer will only communicate events for which valid reporting codes are programmed.

Consult the following table for clarification of this feature:

Reporting Code Entry	Programmed Reporting Codes	Automatic Reporting Codes
00	No Transmission	No Transmission
FF	No Transmission	Automatic reporting code sent
01-FE	01-FE sent	Automatic reporting code sent

If the **SIA Sends Maximum of 8 Events per Round** option is enabled, the dialer will limit its communication round to eight events. This ensures compatibility with all receivers supporting the SIA format. If the **SIA Sends Maximum of 20 Events per Round**, the dialer will send up to 20 events in one round. **NOTE:** Not all receivers will accept this many events. Be sure to check the receiver for compatibility.

Pager Format

Events will be communicated to a pager when using this format.

When programming a pager telephone number, extra digits must be used in order for the feature to function properly. Program two hexadecimal digits 'E' at the end of the telephone number (a 4-second pause). For more information on programming telephone numbers, see Section 4.2.1 "Telephone Numbers".

The panel will attempt to call the pager one time. After dialing the digits in the telephone number the panel will send the account number and reporting code followed by the [#] key (Hex [C]).

There is no ringback when using Pager format. The panel has no way of confirming if the pager was called successfully; a failure to communicate trouble will only be generated once the maximum number of attempts has been reached.

NOTE: Do not use hexadecimal digit C in a reporting code when using Pager Format. In most cases, the digit C will be interpreted as a [#], which will terminate the page before it has finished.

Communication Variables, Sections [081]-[084]

TLM Trouble Delay [081]

This value represents the number of valid checks (10 second interval) required before a telephone line trouble is generated. Valid entries are 000-255, providing trouble annunciation and transmission delays of 10 to 2550 seconds (42.5 minutes).

AC Trouble Delay [082]

This value represents the time (in hours) the communicator waits upon receiving an AC trouble condition from a fire control panel before transmitting it. Valid entries are 000-255 where 000 is disabled.

Maximum Dialing Attempts To Each Telephone Number [083]

This value represents the number of attempts that will be made to each telephone number when communicating. The default value is 007 attempts. Valid entries are 001-015.

Post Dial Wait for Handshake [084]

This value represents the amount of time the communicator will wait for a valid initial handshake from the receiver after dialing the programmed telephone number. The default value is 040 seconds.

Reporting Codes, Sections [201]-[270]

Unless you are using Automatic Contact ID or Automatic SIA formats, reporting codes must be programmed in order for the panel to report events to the central station.

Reporting codes are two digits and can use hexadecimal digits A through F. To disable a reporting code, program it as “FF” (default setting) or “00”. For a complete description of reporting codes which can be programmed and lists of automatic Contact ID and SIA format codes, please see Appendix A: “Reporting Codes”.

Event Buffer, Section [902]

The system’s event buffer can be viewed in the programming mode. Up to 128 events are stored in the buffer memory. The event number will be displayed along with the time and date when the event occurred. Use the [*] key to toggle between the event description and the time and date stamp. Use the arrow keys (< >) to scroll through the events in memory.

Swinger Shutdown, Section [061]

Swinger shutdown levels determine the number of events the dialer will attempt to communicate before the zone is shut down. A 3-digit entry is required, from 000-255. If 000 is programmed, the feature will be disabled and all events will be transmitted. A separate swinger shutdown value is programmed for the following events:

- fire zone alarms/restorals
- supervisory zone alarms/restorals
- zone trouble alarms/restorals
- maintenance troubles/restorals

Test Transmissions, Sections [041]-[042]

The dialer can be programmed to send test transmissions to the monitoring station to verify proper communications.

The **Transmission Time of Day** determines when the test transmission will occur. The entry is four digits (HH:MM). To disable the feature, program the time as [9999].

The **Test Transmission Cycle** will determine the period between test transmissions

NOTE: In order for this feature to function, the panel time and date must be programmed. See Section 4.2.10 “Time & Date” for more information.

Test Transmission Communicator Options [052] #4

If the **Test Transmission Alternates Telephone Lines** option is selected, the dialer will alternate between using Telephone Lines 1 and 2 for transmissions, regardless of telephone line troubles.

If the **Test Transmission Uses First Available Line** option is selected, the dialer will use Telephone Line 1 for transmissions. If a trouble exists on Telephone Line 1, the dialer will switch to Line 2.

Zone Definitions, Section [101]

When using the SIA or Contact ID formats, the control panel zones must be defined in the dialer module. Once the zones are defined, communications of events will include the correct zone type. Each zone type is a 2-digit entry.

The available zone types are as follows:

[01] Fire	[06] Panic	[10] Freeze
[02] Fire Supervisory	[07] Emergency	[11] Heat
[03] Sprinkler	[08] Medical	[12] Water
[04] Burglary	[09] Gas	[13] Untyped
[05] Holdup		

4.2 DLS Programming

4.2.1 [401] Number of Rings to Answer On

This is the number of rings the dialer requires before answering an incoming call. Ring detect supports Line One only. Programming 000 disables ring detect. Valid entries are 000-255. Default is 012.

4.2.2 [402] DLS Double Call Window

This is the maximum amount of time the panel will wait between rings to answer an incoming call with the double call feature. Programming 000 disables this timer. Valid entries are 000-255 seconds. Default is 060.

4.2.3 [403] DLS Download Enable Timer

In order to program the system from a remote computer, this timer must be enabled with 001-254 minutes. When programmed, downloading of the system will be allowed until the timer expires. Uploading of the system information is always enabled. Valid entries are 000-254. Default is 000.

4.2.4 [421] DLS Access Code

This is the access code required by the dialer in order to allow programming from the downloading computer. The access code must be 4 hexadecimal digits in length. Default is 2600.

4.2.5 [422] DLS Panel ID Code

This is the identification code required by the downloading computer to identify the dialer module being programmed. The access code must be 4 hexadecimal digits in length. Default is 2600.

4.3 Panel Programming Section Descriptions

With the addition of the dialer module, the following additional items must be programmed in the control panel. To program these sections, use of the CFP-550 handheld programmer is required. Follow the same procedure for programming as indicated in "Programming using the CFP-550" on page 6. The control panel module address is [02].

NOTE: The installer code will not be required after entering the panel module address.

4.3.1 Zone Programming [001]

This section requires 2 (MR2602) or 5 (MR2605) two-digit entries. Valid entries and description of each entry is shown below.

00 Null Zone

The zone is not used. The zone is not supervised and alarms and troubles are ignored. The End of Line Resistor is not required.

01 Instant

Both smoke detectors and contact devices cause an instant alarm.

02 Auto Verify

Smoke detectors on that zone will be verified before an alarm is initiated. If this type of alarm occurs with an alarm present on the system, or the auto-verify timer is active, this zone will become an instant alarm.

03 Waterflow

Classifies the zone as a waterflow zone. All alarms are instant unless the waterflow delay is enabled. If the delay is enabled, then when a zone goes into alarm a fixed 60 second delay starts. At the end of the delay any waterflow zones still in alarm will cause the panel to go into alarm. The delay will not be restarted on any subsequent waterflow alarms.

04 Supervisory

Classifies the zone as a fire supervisory. All alarms are instant and will turn on the buzzer instead of the bell. Pressing the Trouble Silence Switch silences the supervisory buzzer. If a Supervisory occurs while there is another zone alarm, the Signal Silence switch will silence both the Alarm and Supervisory conditions. Silencing a Supervisory Alarm does not activate the Signal Silenced trouble.

05 Four Wire Smoke (only) Auto Verify

Smoke detectors on that zone will be verified before an alarm is initiated. If this type of alarm occurs with an alarm present on the system, or the auto-verify timer active, this zone will become an instant alarm.

WARNING: *Manual Pull Stations MUST NOT be used on this zone type.*

4.3.2 Panel System Option Code One [011]

[1] NAC1 Output Options

ON = NAC1 is Temporal. NAC1 will sound the Temporal/ANSI Fire Pattern of 0.5 seconds ON, 0.5 seconds Off, 0.5 seconds On, 0.5 seconds Off, 0.5 seconds On, 1.5 seconds Off, repeat.

OFF = NAC1 is Steady. NAC1 will stay on steady for an alarm condition.

[2] NAC2 Output Options

ON = NAC2 is Temporal. NAC2 will sound the Temporal/ANSI Fire Pattern of 0.5 seconds ON, 0.5 seconds Off, 0.5 seconds On, 0.5 seconds Off, 0.5 seconds On, 1.5 seconds Off, repeat.

OFF = NAC2 is Steady. NAC2 will stay on steady for an alarm condition.

[3] NAC Silence Options

ON = Automatic Signal Silence is Enabled. If enabled, the timer starts on the first fire alarm and is restarted on subsequent fire alarms from other zones. When the timer reaches 30 minutes from the last fire alarm, the NAC's are restored to normal. If after the panel has been silenced, either manually or automatically, another alarm occurs it will restart the timer for a full timing period.

OFF = Automatic Signal Silence is Disabled. The NAC's will continue to sound until the Signal Silence key is pressed.

[4] NAC2 Strobe Options

ON = NAC2 is a Strobe. NAC2 is restored to normal following a successful System Reset.

OFF = NAC2 is a Standard Bell. NAC2 is restored to normal following a Signal Silence.

[5] Signal Silence Inhibit Options

ON = Signal Silence Inhibit Timer is Enabled. While in force, this timer prevents manual signal silencing for 60 seconds. The timer is started on the first alarm only and is not restarted on subsequent alarms. If after manual or automatic silencing (no reset) a subsequent alarm occurs, the Silence Inhibit timer is not started. This timer is only started on the first fire alarm after a successful panel reset.

OFF = Signal Silence Inhibit Timer is Disabled. The Signal Silence key will silence the alarm.

[6] Walk Test Audible Options

ON = Walk test is Audible. On a fire or supervisory alarm the NAC's will pulse once – ¼ sec. On a zone or system trouble, except ground fault, the NAC's will sound twice – ¼ ON, ¼ OFF, ¼ ON and OFF. For ground fault the NAC's will sound three times – ¼ ON, ¼ OFF, ¼ ON, ¼ OFF, ¼ ON and OFF.

OFF = Walk test is Silent. The NAC's will not sound during walk test.

[7] Waterflow Zone Delay Options

ON = Waterflow Zone Alarms are Delayed. The Waterflow delay is a fixed timer - 60 seconds - and applies to all zones that are set as zone type "waterflow". The first waterflow zone to go into alarm will start the timer and it is not restarted on subsequent waterflow alarms from another waterflow zone. When the timer expires, any waterflow type zone still in alarm will cause the panel to go into alarm. If during the waterflow delay period, any other type of fire zone goes into alarm, the panel will immediately go into alarm in response to that zone.

OFF = Waterflow Zone Alarms are not Delayed. Zone's programmed as "waterflow" will go into alarm instantly.

[8] Waterflow Zone Silence Options

ON = Waterflow Zones can be Silenced. Regardless of their state, the NAC's can be silenced. This applies to both manual and automatic signal silence.

OFF = Waterflow Zones cannot be Silenced. Until physically restored, the NAC's can't be silenced. This applies to both manual and automatic signal silence. However, If the zone enters the trouble state (open) following the alarm (short) and alarm restore, the zone shall be silenceable.

4.3.3 Panel System Option Code Two [012]

[1] Auto Verify Fault Options

ON = Auto Verify Fault is Alarm. If a zone initiates an auto verify sequence and returns from power down in the open (trouble) state, the system will treat this as an alarm condition and assume that the circuit has been forced open by fire.

OFF = Auto Verify Fault is Trouble. If a zone initiates an auto verify sequence and returns from power down in the open (trouble) state, the system will treat this as a trouble condition.

[2]-[6] For Future Use

[7] Crystal Time Base Options

ON = Crystal Time Base Used. The panel will use the crystal for time keeping.

OFF = AC Time Base Used. The panel will use the AC to for time keeping.

WARNING: When using Crystal Time Base the Clock Adjust feature should be used.

[8] Daylight Savings Options

ON = Daylight Savings Time Enabled. The panel will adjust between daylight and standard times on the first Sunday in April (ahead one hour) and the last Sunday in October (behind one hour) @ 2:00 a.m. These dates and times are hard-coded.

OFF = Daylight Savings Time Disabled. The panel will make no automatic time adjustments for daylight savings time.

4.3.4 Clock Adjust , Section [091]

This 3-digit value is used for any time correction required due to inaccuracies of the crystal time keeper. The adjustment is made to the last minute before midnight. The default setting is [060] (seconds), representing no adjustment in the clock time.

Example: If the clock were running fast by 35 seconds a day, set the clock adjust value at [95]. This would ensure that the last minute before midnight would be 95 seconds long, thus increasing the day by 35 seconds. If the clock were running slow by 45 seconds a day, then set this value for [15].

WARNING: *In order for the test transmission feature in the dedicated dialer to operate properly, the time and date must be programmed in the panel. The daylight savings and clock adjust features should be taken into consideration as well.*

4.3.5 Time & Date, Section [901]

Enter the system time in 24-hour format. Enter the date with two decimals each for the month and day and four decimals for the year. (HH:MM MM/DD/YYYY)

Valid entries for the hour are 00-23. Valid entries for the minute are 00-59.

4.3.6 Event Buffer Viewing [902]

When entering this section, the 20 event buffer memory can be viewed. Upon entry, the event number will be displayed along with the time and date stamp of when that event occurred. Pressing the [*] key will display the event description. Pressing [*] again will toggle back to the event number with date and time stamp. Pressing the [<] key or the [>] key will scroll through the event buffer with event 001 being the first and event 20 being the last.

4.3.7 Module Supervisory Reset [903]

When entering this section, the module supervisory field in the FACP will be erased and all modules will re-enroll. This will clear any module troubles on the system. This must be done when removing a module from the system.

4.3.8 Default [999]

When this section is entered, the FACP will be returned to the factory defaults.

4.3.9 Crystal Time Base Options , Section [012] #7

If the option is turned ON, the panel will use the crystal for time keeping. If the option is OFF, the panel will use AC for time keeping. If crystal time keeping is selected, check whether the clock needs to be adjusted.

4.3.10 Daylight Savings Options , Section [012] #8

If the option is turned ON, the panel will adjust between daylight and standard times on the appropriate days (first Sunday in April ahead one hour, last Sunday in October behind one hour). If the option is disabled, the panel will make no automatic adjustments.

Section 5: Programming Worksheets

5.1 Dialer Programming Worksheets

[000] Installer's Access Code (4 digits)

Default

2600

[001] First Telephone Number(32 digits)

[002] Second Telephone Number (32 digits)

[003] Third Telephone Number (32 digits)

[011] First Telephone Number Account Code (4 digits)

[012] Second Telephone Number Account Code (4 digits)

[021] Communicator Format Options

01	10 bps, 1400 Hz handshake	05	Contact I.D.
02	10 bps, 2300 Hz handshake	06	SIA
03	20 bps, 1400 Hz handshake	07	Pager
04	20 bps, 2300 Hz handshake		

NOTE: Telephone Number 3 follows the format of the Telephone Number 1

Default

06 1st Phone Number

06 2nd Phone Number

[031] Fire Zone Alarm/Restore Communicator Call Directions

Default		Option ON	Option OFF
OFF	<input type="checkbox"/> Options 1-6	Future Use	
OFF	<input type="checkbox"/> Option 7	Telephone Number 2	Disabled
ON	<input type="checkbox"/> Option 8	Telephone Number 1	Disabled

[032] Supervisory Zone Alarm/Restore Communicator Call Directions

Default		Option ON	Option OFF
OFF	<input type="checkbox"/> Options 1-6	Future Use	
OFF	<input type="checkbox"/> Option 7	Telephone Number 2	Disabled
ON	<input type="checkbox"/> Option 8	Telephone Number 1	Disabled

[033] Zone Trouble/Restore Communicator Call Directions

Default		Option ON	Option OFF
OFF	<input type="checkbox"/> Options 1-6	Future Use	
OFF	<input type="checkbox"/> Option 7	Telephone Number 2	Disabled
ON	<input type="checkbox"/> Option 8	Telephone Number 1	Disabled

[034] Maintenance Trouble/Restore Communicator Call Directions

Default		Option ON	Option OFF
OFF	<input type="checkbox"/> Options 1-6	Future Use	
OFF	<input type="checkbox"/> Option 7	Telephone Number 2	Disabled
ON	<input type="checkbox"/> Option 8	Telephone Number 1	Disabled

[035] Test Transmission Communicator Call Directions

Default		Option ON	Option OFF
OFF	<input type="checkbox"/> Options 1-6	Future Use	
OFF	<input type="checkbox"/> Option 7	Telephone Number 2	Disabled
ON	<input type="checkbox"/> Option 8	Telephone Number 1	Disabled

[041] Test Transmission Time Of Day

Default
 9999 (Valid entries are 0000-2359; 9999 to disable)

[042] Test Transmission Cycle

Default
 030 (000-255 days)

[051] First Communicator Options Code

Default		Option ON	Option OFF
ON	<input type="checkbox"/> Option 1	Future use - MUST be enabled	
ON	<input type="checkbox"/> Option 2	Future use - MUST be enabled	
ON	<input type="checkbox"/> Option 3	Future use - MUST be enabled	
OFF	<input type="checkbox"/> Option 4	3rd Phone Number Enabled	3rd Phone Number Disabled
OFF	<input type="checkbox"/> Option 5	Alternate Dial (1st & 3rd)	Call 1st Number, Backup to 3rd
OFF	<input type="checkbox"/> Option 6	Pulse Dialing	DTMF Dialing
OFF	<input type="checkbox"/> Option 7	Switch to Pulse Dialing On 4th Attempt	DTMF Dial For All Attempts
ON	<input type="checkbox"/> Option 8	Event Buffer Follows Swinger Shutdown	Event Buffer Always Logs Events

[052] Second Communicator Options Code

Default		Option ON	Option OFF
OFF	<input type="checkbox"/> Option 1	SIA Uses Programmed Rep. Codes	SIA Uses Automatic Rep. Codes
OFF	<input type="checkbox"/> Option 2	SIA Sends Max Of 20 Events Per Round	SIA Sends Max Of 8 Events Per Round
OFF	<input type="checkbox"/> Option 3	Contact ID Uses Programmed Rep. Code	Contact ID Uses Automatic Rep. Codes
ON	<input type="checkbox"/> Option 4	Test Transmission Uses Alternate Lines	Test Transmission Uses Available Line
OFF	<input type="checkbox"/> Option 5	Future use	
OFF	<input type="checkbox"/> Option 6	Future use	
OFF	<input type="checkbox"/> Option 7	DLS Callback Enabled	DLS Callback Disabled
OFF	<input type="checkbox"/> Option 8	DLS Double Call Enabled	DLS Double Call Disabled

[053] Intertional Communicator Options Code

Default	Option ON	Option OFF
OFF <input type="checkbox"/> Option 1	Force Dialing Enabled	Force Dialing Disabled
OFF <input type="checkbox"/> Option 2	Busy Tone Detection Enabled	Busy Tone Detection Disabled
OFF <input type="checkbox"/> Option 3	Pulse Dialing Make/Break Ratio is 33/67	Pulse Dialing Make/Break Ratio is 40/60
OFF <input type="checkbox"/> Option 4	1600 Hz Handshake	Standard Handshake
OFF <input type="checkbox"/> Option 5	ID Tone Enabled	ID Tone Disabled
OFF <input type="checkbox"/> Option 6	2100 Hz ID Tone	1300 Hz ID Tone
OFF <input type="checkbox"/> Option 7	Future use	
OFF <input type="checkbox"/> Option 8	Future use	

[061] Swinger Shutdown Variables

Default	
000 <input type="text"/> <input type="text"/> <input type="text"/> <input type="text"/>	Zone Alarm/Restore (Valid Entries are 000-255)
000 <input type="text"/> <input type="text"/> <input type="text"/> <input type="text"/>	Zone Supervisory/Restore
000 <input type="text"/> <input type="text"/> <input type="text"/> <input type="text"/>	Zone Trouble/Restore
000 <input type="text"/> <input type="text"/> <input type="text"/> <input type="text"/>	Maintenance Trouble/Restore

[081] TLM Trouble Delay

Default	
003 <input type="text"/> <input type="text"/> <input type="text"/> <input type="text"/>	Number of valid checks required = 001-255 x 10 seconds

[082] AC Trouble Delay

Default	
000 <input type="text"/> <input type="text"/> <input type="text"/> <input type="text"/>	(Valid entries are 000-255 hours)

[083] Maximum Dialing Attempts To Each Phone Number

Default	
007 <input type="text"/> <input type="text"/> <input type="text"/> <input type="text"/>	(Valid entries are 001-015 attempts)

[084] Post Dial Wait For Handshake (all formats)

Default	
040 <input type="text"/> <input type="text"/> <input type="text"/> <input type="text"/>	(Valid entries are 001-255 seconds)

Zone Definitions

00 Null Zone (Not Used)	04 Burglary	08 Medical	11 Heat
01 Fire	05 Holdup	09 Gas	12 Water
02 Fire Supervisory	06 Panic	10 Freeze	13 Untyped
03 Sprinkler	07 Emergency		

[101] Zone 1-5 Definitions

Default		Default	
13 <input type="text"/> <input type="text"/> <input type="text"/> <input type="text"/>	Zone 1	13 <input type="text"/> <input type="text"/> <input type="text"/> <input type="text"/>	Zone 4
13 <input type="text"/> <input type="text"/> <input type="text"/> <input type="text"/>	Zone 2	13 <input type="text"/> <input type="text"/> <input type="text"/> <input type="text"/>	Zone 5
13 <input type="text"/> <input type="text"/> <input type="text"/> <input type="text"/>	Zone 3		

[201] Alarm Reporting Codes, Zones 1-5

<input type="text"/>	Zone 1 Alarm	<input type="text"/>	Zone 4 Alarm
<input type="text"/>	Zone 2 Alarm	<input type="text"/>	Zone 5 Alarm
<input type="text"/>	Zone 3 Alarm		

[217] Alarm Restoral Reporting Codes, Zones 1-5

<input type="text"/>	Zone 1 Alarm Restoral	<input type="text"/>	Zone 4 Alarm Restoral
<input type="text"/>	Zone 2 Alarm Restoral	<input type="text"/>	Zone 5 Alarm Restoral
<input type="text"/>	Zone 3 Alarm Restoral		

[233] Trouble Reporting Codes, Zones 1-5

<input type="text"/>	Zone 1 Trouble	<input type="text"/>	Zone 4 Trouble
<input type="text"/>	Zone 2 Trouble	<input type="text"/>	Zone 5 Trouble
<input type="text"/>	Zone 3 Trouble		

[249] Trouble Restoral Reporting Codes, Zones 1-5

<input type="text"/>	Zone 1 Trouble Restoral	<input type="text"/>	Zone 4 Trouble Restoral
<input type="text"/>	Zone 2 Trouble Restoral	<input type="text"/>	Zone 5 Trouble Restoral
<input type="text"/>	Zone 3 Trouble Restoral		

[265] Maintenance Alarm Reporting Codes

<input type="text"/>	AC Failure Trouble Alarm	<input type="text"/>	General System Trouble
<input type="text"/>	Battery Trouble Alarm	<input type="text"/>	General System Supervisory
<input type="text"/>	Ground Fault Trouble Alarm	<input type="text"/>	Secur-bus Trouble
<input type="text"/>	NAC Trouble Alarm		

[266] Maintenance Alarm Restoral Reporting Codes

<input type="text"/>	AC Failure Trouble Restoral	<input type="text"/>	General System Trouble Restore
<input type="text"/>	Battery Trouble Restoral	<input type="text"/>	General System Supervisory Restore
<input type="text"/>	Ground Fault Trouble Restoral	<input type="text"/>	Secur-bus Trouble Restore
<input type="text"/>	NAC Trouble Restoral		

[267] Dedicated Maintenance Alarm Reporting Codes

<input type="text"/>	TLM 1 Trouble Alarm	<input type="text"/>	FTC Phone 1 Trouble Alarm
<input type="text"/>	TLM 2 Trouble Alarm	<input type="text"/>	FTC Phone 2 Trouble Alarm

[268] Dedicated Maintenance Alarm Restoral Reporting Codes

<input type="text"/>	TLM 1 Trouble Restoral	<input type="text"/>	FTC Phone 1 Trouble Restoral
<input type="text"/>	TLM 2 Trouble Restoral	<input type="text"/>	FTC Phone 2 Trouble Restoral

[269] Test Trouble and Test Trouble Restoral Reporting Codes

<input type="text"/>	Walk Test Start	<input type="text"/>	DLS Lead In
<input type="text"/>	Walk Test Stop	<input type="text"/>	DLS Lead Out
<input type="text"/>	Installer's Lead In		
<input type="text"/>	Installer's Lead Out		

[270] Test Transmission Reporting Codes

<input type="text"/>	System Normal Test Transmission	<input type="text"/>	System Off-Normal Test Transmission
----------------------	---------------------------------	----------------------	-------------------------------------

5.2 Panel Programming Worksheets

[001] Zone 1-16 Definitions

Zone Definitions

00	Null zone (not used)	03	Waterflow
01	Instant Fire	04	Supervisory
02	Verify Fire	05	4-Wire Verify Fire

Default

01 Zone 1
 01 Zone 2
 01 Zone 3

Default

01 Zone 4
 01 Zone 5

[011] First Panel Options Code

Default

OFF Option 1
 OFF Option 2
 OFF Option 3
 OFF Option 4
 OFF Option 5
 ON Option 6
 OFF Option 7
 ON Option 8

Option ON

NAC1 is Temporal
 NAC2 is Temporal
 30 min. Automatic Signal Silence Enabled
 NAC2 is Strobe
 60 sec. Signal Silence Inhibit Enabled
 Walk Test is Audible
 60 sec. Waterflow Zone Delay Enabled
 Active Waterflow Zones can be Silenced

Option OFF

NAC1 is Steady
 NAC2 is Steady
 Automatic Signal Silence Disabled
 NAC2 is Standard Bell
 Signal Silence Inhibit Disabled
 Walk Test is Silent
 Waterflow Zone Delay Disabled
 Active Waterflow Zones not Silenceable

[012] Second Panel Options Code

Default

ON Option 1
 OFF Options 2-6
 OFF Option 7
 OFF Option 8

Option ON

Zone Trouble Auto Verifies Alarm
 Future use
 Crystal Time Base Used
 Daylight Savings Enabled

Option OFF

Zone Trouble Does not Auto Verify Alarm

 AC Time Base Used
 Daylight Savings Disabled

[091] Clock Adjust

Default

060 (001-255 seconds)

[091] System Time and Date

Default

00:00 01 / 01 / 1999
 HH:MM MM / DD / YYYY

: / /

[902] FACP Event Buffer Viewing

[903] Module Supervisory Reset

[999] FACP Default

Section 6: Warranty and Warning Information

6.1 Warning

Please Read Carefully

Note to Installers

This warning contains vital information. As the only individual in contact with system users, it is your responsibility to bring each item in this warning to the attention of the users of this system. Failure to properly inform system end-users of the circumstances in which the system might fail may result in over-reliance upon the system. As a result, it is imperative that you properly inform each customer for whom you install the system of the possible forms of failure.

System Failures

This system has been carefully designed to be as effective as possible. There are circumstances, such as fire or other types of emergencies where it may not provide protection. Alarm systems of any type may be compromised deliberately or may fail to operate as expected for a variety of reasons. Some reasons for system failure include:

- **Inadequate Installation**

A Fire Alarm system must be installed in accordance with all the applicable codes and standards in order to provide adequate protection. An inspection and approval of the initial installation, or, after any changes to the system, must be conducted by the Local Authority Having Jurisdiction. Such inspections ensure installation has been carried out properly.
- **Power Failure**

Control units, smoke detectors and many other connected devices require an adequate power supply for proper operation. If the system or any device connected to the system operates from batteries, it is possible for the batteries to fail. Even if the batteries have not failed, they must be fully charged, in good condition and installed correctly. If a device operates only by AC power, any interruption, however brief, will render that device inoperative while it does not have power. Power interruptions of any length are often accompanied by voltage fluctuations which may damage electronic equipment such as a fire alarm system. After a power interruption has occurred, immediately conduct a complete system test to ensure that the system operates as intended.
- **Failure of Replaceable Batteries**

Systems with wireless transmitters have been designed to provide several years of battery life under normal conditions. The expected battery life is a function of the device environment, usage and type. Ambient conditions such as high humidity, high or low temperatures, or large temperature fluctuations may reduce the expected battery life. While each transmitting device has a low battery monitor which identifies when the batteries need to be replaced, this monitor may fail to operate as expected. Regular testing and maintenance will keep the system in good operating condition.
- **Compromise of Radio Frequency (Wireless) Devices**

Signals may not reach the receiver under all circumstances which could include metal objects placed on or near the radio path or deliberate jamming or other inadvertent radio signal interference.
- **System Users**

A user may not be able to operate a panic or emergency switch possibly due to permanent or temporary physical disability, inability to reach the device in time, or unfamiliarity with the correct operation. It is important that all system users be trained in the correct operation of the alarm system and that they know how to respond when the system indicates an alarm.
- **Automatic Alarm Initiating Devices**

Smoke detectors, heat detectors and other alarm initiating devices that are a part of this system may not properly detect a fire condition or signal the control panel to alert occupants of a fire condition for a number of reasons, such as: the smoke detectors or heat detector may have been improperly installed or positioned; smoke or heat may not be able to reach the alarm initiating device, such as when the fire is in a chimney, walls or roofs, or on the other side of closed doors; and, smoke and heat detectors may not detect smoke or heat from fires on another level of the residence or building. Every fire is different in the amount and rate at which smoke and heat are generated. Smoke detectors cannot sense all types of fires equally well. Smoke detectors may not provide timely warning of fires caused by carelessness or safety hazards such as smoking in bed, violent explosions, escaping gas, improper storage of flammable materials, overloaded electrical circuits, children playing with matches or arson.

Even if the smoke detector or heat detector operates as intended, there may be circumstances when there is insufficient warning to allow all occupants to escape in time to avoid injury or death.
- **Alarm Notification Appliances**

Alarm Notification Appliances such as sirens, bells, horns, or strobes may not warn people or waken

someone sleeping if there is an intervening wall or door. If notification appliances are located on a different level of the residence or premise, then it is less likely that the occupants will be alerted or awakened. Audible notification appliances may be interfered with by other noise sources such as stereos, radios, televisions, air conditioners or other appliances, or passing traffic. Audible notification appliances, however loud, may not be heard by a hearing-impaired person.

- **Telephone Lines**

If telephone lines are used to transmit alarms, they may be out of service or busy for certain periods of time. Also the telephone lines may be compromised by such things as criminal tampering, local construction, storms or earthquakes.

- **Insufficient Time**

There may be circumstances when the system will operate as intended, yet the occupants will not be protected from the emergency due to their inability to respond to the warnings in a timely manner. If the system is monitored, the response may not occur in time enough to protect the occupants or their belongings.

- **Component Failure**

Although every effort has been made to make this system as reliable as possible, the system may fail to function as intended due to the failure of a component.

- **Inadequate Testing**

Most problems that would prevent an alarm system from operating as intended can be discovered by regular testing and maintenance. The complete system should be tested as required by national standards and the Local Authority Having Jurisdiction and immediately after a fire, storm, earthquake, accident, or any kind of construction activity inside or outside the premises. The testing should include all sensing devices, keypads, consoles, alarm indicating devices and any other operational devices that are part of the system.

- **Security and Insurance**

Regardless of its capabilities, an alarm system is not a substitute for property or life insurance. An alarm system also is not a substitute for property owners, renters, or other occupants to act prudently to prevent or minimize the harmful effects of an emergency situation.

IMPORTANT NOTE: End-users of the system must take care to ensure that the system, batteries, telephone lines, etc. are tested and examined on a regular basis to ensure the minimization of system failure.

6.2 Limited Warranty

Digital Security Controls Ltd. warrants the original purchaser that for a period of twelve months from the date of purchase, the product shall be free of defects in materials and workmanship under normal use. During the warranty period, Digital Security Controls Ltd. shall, at its option, repair or replace any defective product upon return of the product to its factory, at no charge for labor and materials. Any replacement and/or repaired parts are warranted for the remainder of the original warranty or ninety (90) days, whichever is longer. The original owner must promptly notify Digital Security Controls Ltd. in writing that there is defect in material or workmanship, such written notice to be received in all events prior to expiration of the warranty period.

International Warranty

The warranty for international customers is the same as for any customer within Canada and the United States, with the exception that Digital Security Controls Ltd. shall not be responsible for any customs fees, taxes, or VAT that may be due.

Warranty Procedure

To obtain service under this warranty, please return the item(s) in question to the point of purchase. All authorized distributors and dealers have a warranty program. Anyone returning goods to Digital Security Controls Ltd. must first obtain an authorization number. Digital Security Controls Ltd. will not accept any shipment whatsoever for which prior authorization has not been obtained.

Conditions to Void Warranty

This warranty applies only to defects in parts and workmanship relating to normal use. It does not cover:

- damage incurred in shipping or handling;
- damage caused by disaster such as fire, flood, wind, earthquake or lightning;
- damage due to causes beyond the control of Digital Security Controls Ltd. such as excessive voltage, mechanical shock or water damage;
- damage caused by unauthorized attachment, alterations, modifications or foreign objects;
- damage caused by peripherals (unless such peripherals were supplied by Digital Security Controls Ltd.);
- defects caused by failure to provide a suitable installation environment for the products;
- damage caused by use of the products for purposes other than those for which it was designed;
- damage from improper maintenance;
- damage arising out of any other abuse, mishandling or improper application of the products.

Digital Security Controls Ltd.'s liability for failure to repair the product under this warranty after a reasonable number of attempts will be limited to a replacement of the product, as the exclusive remedy for breach of warranty. Under no circumstances shall Digital Security Controls Ltd. be liable for any special, incidental, or consequential damages based upon breach of warranty, breach of contract, negligence, strict liability, or any other legal theory. Such damages include, but are not limited to, loss of profits, loss of the product or any associated equipment, cost of capital, cost of substitute or replacement equipment, facilities or services, down time, purchaser's time, the claims of third parties, including customers, and injury to property.

Disclaimer of Warranties

This warranty contains the entire warranty and shall be in lieu of any and all other warranties, whether expressed or implied (including all implied warranties of merchantability or fitness for a particular purpose) And of all other obligations or liabilities on the part of Digital Security Controls Ltd. neither assumes responsibility for, nor authorizes any other person purporting to act on its behalf to modify or to change this warranty, nor to assume for it any other warranty or liability concerning this product.

This disclaimer of warranties and limited warranty are governed by the laws of the province of Ontario, Canada.

WARNING: Digital Security Controls Ltd. recommends that the entire system be completely tested on a regular basis. However, despite frequent testing, and due to, but not limited to, criminal tampering or electrical disruption, it is possible for this product to fail to perform as expected.

Out of Warranty Repairs

Digital Security Controls Ltd. will at its option repair or replace out-of-warranty products which are returned to its factory according to the following conditions. Anyone returning goods to Digital Security Controls Ltd. must first obtain an authorization number. Digital Security Controls Ltd. will not accept any shipment whatsoever for which prior authorization has not been obtained.

Products which Digital Security Controls Ltd. determines to be repairable will be repaired and returned. A set fee which Digital Security Controls Ltd. has predetermined and which may be revised from time to time, will be charged for each unit repaired.

Products which Digital Security Controls Ltd. determines not to be repairable will be replaced by the nearest equivalent product available at that time. The current market price of the replacement product will be charged for each replacement unit.

Appendix A: Table of Reporting Codes

The following tables contain automatic Contact ID and SIA format reporting codes. For more information on reporting formats, see Section 4.3.5 “Communicator Format Options”.

Contact ID

The first digit (in parentheses) will automatically be sent by the control. The second two digits are programmed to indicate specific information about the signal.

For example, if zone 1 is an fire zone point, you could program the event code as [1A]. The central station would receive the following:

FIRE - FIRE ALARM - 1

where the “1” indicates which zone went into alarm.

SIA Format – Level 2 (Hardcoded)

The SIA communication format used in this product follows the Level 2 specifications of the SIA Digital Communication Standard – October 1997. This format will send the account code along with its data transmission. The transmission would look similar to the following at the receiver:

```
N Ri00 FA 01
N      = New Event
Ri00   = System Event
FA     = Fire Alarm
01     = Zone 1
```

Table 1: Automatic Contact ID/SIA Reporting Codes

Section #	Reporting Code	Code Sent When...	Dialer Direction*	Contact ID Auto Rep Codes	Sia Auto Rep Codes
[201] & [217]	Zone Supv./Rest.	zone goes into supervisory/ restore	S/R	(2) AA	See Table 3
[201] & [217]	Zone Alarms/Rest.	zone goes into alarm/ alarm condition has been restored	A/R	(1) 3A	See Table 3
[233] & [249]	Zone Trouble/Rest.	zone exhibits a trouble condition/ zone trouble condition has been restored	T/R	(3) 73	See Table 3
[265] & [266]	AC Fail Trouble/Rest.	AC power to control panel is disconnected or interrupted/AC power restored; both codes follow the AC Trouble Delay	MA/R	(3) A1	AT-00/AR-00
[265] & [266]	Battery Trouble/Rest.	control panel battery is low/battery restored	MA/R	(3) A2	YT-00/YR-00
[265] & [266]	Ground Fault Trouble/Rest.	Earth Ground Fault is detected/restored	MA/R	(3) 1A	UT-00/UJ-00
[265] & [266]	NAC Trouble/Rest.	NAC circuit is opened/restored	MA/R	(3) 21	YA-99/YH-99
[265] & [266]	General System Trouble/Rest.	module trouble is detected/restored	MA/R	(3) 3A	YX-00/YZ-00
[265] & [266]	Gen. System Supervisory/Rest.	control panel loses/restores communications to enrolled modules	MA/R	(3) 33	ET-00/ER-00
[265] & [266]	Secur-bus Trouble/Rest.	Secur-bus connection is lost/restored	MA/R	(3) 33	NT-00/NR-00
[267] & [268]	Line 1 or 2 TLM Trouble/Rest.	connection via Telephone Numbers 1 or 2 is lost/restored	MA/R	(3) 51	LT-XX/LR-XX**
[267] & [268]	Phone # 1 or 2 FTC Trouble/Rest.	communication is restored after a failure to communicate trouble has occurred; events not communicated during lapse will also be sent	MA/R	(3) 54	YC-XX/YK-XX**
[269]	Walk Test Start/Stop	control panel has entered/exited walk test mode; no events will be communicated	MA/R	(6) A7	TS-00/TE-00
[269]	Installer Lead In/Out	control panel enters/exits programming mode	MA/R	(6) 27/28	LB-00/LX-00
[269]	DLS Lead In/Out	remote computer connects/disconnects from the system	MA/R	(4) 12	RB-00/RS-00
[270]	Test Transmission Normal/Off-Normal	test transmission reports system normal or off-normal (alarm, supervisory or trouble) control panel condition	T	(6) A2	RP-00/RY-00

* Call directions: A/R = alarm/restoral; T/R = trouble/restoral; MA/R = maintenance alarm/restoral; S/R = supervisory/restore; T = test transmission

** Line number/telephone number is identified (XX)

Table 2: Contact ID Zone Alarm/Restoral Event Codes

Program any of these codes for zone alarms/restorals when using the standard (i.e. not automatic) Contact ID reporting format:

Medical Alarms	(1)18 Near Alarm	24 Hour Non-Fire
(1)A1 Emergency	Panic Alarms	(1)51 Gas Detected
(1)A2 Fail to Report In	(1)2A Panic	(1)52 Refrigeration
Fire Alarms	(1)21 Duress	(1)53 Loss of Heat
(1)1A Fire Alarm	(1)22 Silent	(1)54 Water Leakage
(1)11 Smoke	(1)23 Audible	(1)55 Foil Break
(1)12 Combustion	General Alarms	(1)56 Day Trouble
(1)13 Water Flow	(1)4A General Alarm	(1)57 Low Bottled Gas Level
(1)14 Heat	(1)4A General Alarm	(1)58 High Temp
(1)15 Pull Station	(1)43 Expansion module failure	(1)59 Low Temp
(1)16 Duct	(1)44 Sensor tamper	(1)61 Loss of Air Flow
(1)17 Flame	(1)45 Module Tamper	

Table 3: SIA Format Automatic Zone Alarm/Restoral Codes

Zone Definition	Alarm/Rest. Rep Codes*	Trouble/Rest. Rep Codes	Zone Definition	SIA Auto Rep Codes*	Trouble/Rest. Rep Codes
[00] Null Zone	No transm.	No transm.	[09] Gas	GA-ZZ/GH-ZZ	GT-ZZ/GJ-ZZ
[01] Fire	FA-ZZ/FH-ZZ	FT-ZZ/FJ-ZZ	[10] Freeze	ZA-ZZ/ZH-ZZ	ZT-ZZ/ZJ-ZZ
[02] Fire Supervisory	FS-ZZ/FR-ZZ	FT-ZZ/FJ-ZZ	[11] Heat	KA-ZZ/KH-ZZ	KT-ZZ/KJ-ZZ
[03] Sprinkler	SA-ZZ/SH-ZZ	ST-ZZ/SJ-ZZ	[12] Water	WA-ZZ/WH-ZZ	WT-ZZ/WJ-ZZ
[06] Panic	PA-ZZ/PH-ZZ	PT-ZZ/PJ-ZZ	[13] Untyped	UA-ZZ/UH-ZZ	UT-ZZ/UJ-ZZ
[07] Emergency	QA-ZZ/QH-ZZ	QT-ZZ/QJ-ZZ			

ZZ = zones 01-05

Appendix B: Table of Compatible Receivers

Format/Receiver	Sur-Gard SLR	Sur-Gard MLR	Sur-Gard MLR2000	Osbourne Hoffman Quick Alert II	Silent Knight	Ademco 685	Radionics 6500	Bell Mobility Pager
10 bps (1400Hz handshake)	Yes	Yes	Yes	Yes	Yes	Yes	Yes	
10 bps (2300Hz handshake)	Yes	Yes	Yes	Yes	Yes	Yes	Yes	
20 bps (1400Hz handshake)	Yes	Yes	Yes	Yes	Yes	Yes	Yes	
20 bps (2300Hz handshake)	Yes	Yes	Yes	Yes	Yes	Yes	Yes	
SIA (level 2)	Yes	Yes	Yes	Yes	Yes			
Contact ID	Yes	Yes	Yes	Yes		Yes		
Pager	N/A	N/A	N/A	N/A	N/A	N/A	N/A	Yes
Version	V1.00	V1.83	V1.2	2/20/96	SIA-90041-960626	Rev4.4d	D6500 L/C 1993	

NOTE: Pager format is to be used for backup troubles only.

FCC COMPLIANCE STATEMENT

CAUTION: Changes or modifications not expressly approved by the manufacturer could void your authority to use this equipment.

This equipment has been tested and found to comply with the limits for a Class B digital device, pursuant to Part 15 of the FCC Rules. These limits are designed to provide reasonable protection against harmful interference in a residential installation. This equipment generates, uses and can radiate radio frequency energy and, if not installed and used in accordance with the instructions, may cause harmful interference to radio communications. However, there is no guarantee that interference will not occur in a particular installation. If this equipment does cause harmful interference to radio or television reception, which can be determined by turning the equipment off and on, the user is encouraged to try to correct the interference by one or more of the following measures:

- Re-orient the receiving antenna.
- Increase the separation between the equipment and receiver.
- Connect the equipment into an outlet on a circuit different from that to which the receiver is connected.
- Consult the dealer or an experienced radio/television technician for help.

The user may find the following booklet prepared by the FCC useful: "How to Identify and Resolve Radio/Television Interference Problems". This booklet is available from the U.S. Government Printing Office, Washington D.C. 20402, Stock # 004-000-00345-4.

The user may find the following booklet prepared by the FCC useful: "How to Identify and Resolve Radio/Television Interference Problems". This booklet is available from the U.S. Government Printing Office, Washington D.C. 20402, Stock # 004-000-00345-4.

important information

This equipment complies with Part 68 of the FCC Rules. On the side of this equipment is a label that contains, among other information, the FCC registration number of this equipment.

NOTIFICATION TO TELEPHONE COMPANY The customer shall notify the telephone company of the particular line to which the connection will be made, and provide the FCC registration number and the ringer equivalence of the protective circuit.

FCC Registration Number: F53CAN-28070-AL-E Ringer Equivalence Number: 0.1B USOC Jack: RJ-31X

TELEPHONE CONNECTION REQUIREMENTS Except for the telephone company provided ringers, all connections to the telephone network shall be made through standard plugs and telephone company provided jacks, or equivalent, in such a manner as to allow for easy, immediate disconnection of the terminal equipment. Standard jacks shall be so arranged that, if the plug connected thereto is withdrawn, no interference to the operation of the equipment at the customer's premises which remains connected to the telephone network shall occur by reason of such withdrawal.

INCIDENCE OF HARM Should terminal equipment or protective circuitry cause harm to the telephone network, the telephone company shall, where practicable, notify the customer that temporary disconnection of service may be required; however, where prior notice is not practicable, the telephone company may temporarily discontinue service if such action is deemed reasonable in the circumstances. In the case of such temporary discontinuance, the telephone company shall promptly notify the customer and will be given the opportunity to correct the situation.

ADDITIONAL TELEPHONE COMPANY INFORMATION The security control panel must be properly connected to the telephone line with a USOC RJ-31X telephone jack.

The FCC prohibits customer-provided terminal equipment be connected to party lines or to be used in conjunction with coin telephone service. Interconnect rules may vary from state to state.

CHANGES IN TELEPHONE COMPANY EQUIPMENT OR FACILITIES The telephone company may make changes in its communications facilities, equipment, operations or procedures, where such actions are reasonably required and proper in its business. Should any such changes render the customer's terminal equipment incompatible with the telephone company facilities the customer shall be given adequate notice to the effect modifications to maintain uninterrupted service.

RINGER EQUIVALENCE NUMBER (REN) The REN is useful to determine the quantity of devices that you may connect to your telephone line and still have all of those devices ring when your telephone number is called. In most, but not all areas, the sum of the RENs of all devices connected to one line should not exceed five (5.0). To be certain of the number of devices that you may connect to your line, you may want to contact your local telephone company.

EQUIPMENT MAINTENANCE FACILITY If you experience trouble with this telephone equipment, please contact the facility indicated below for information on obtaining service or repairs. The telephone company may ask that you disconnect this equipment from the network until the problem has been corrected or until you are sure that the equipment is not malfunctioning.

Digital Security Controls Ltd. 160 Washburn St., Lockport, NY 14094



©2001 Digital Security Controls Ltd.
Toronto, Canada
Tech. Line (Canada & US): 1-800-387-3630 • www.dsc.com
Printed in Canada 29005860 R002